



# FITTING INSTRUCTIONS

<b>Product:</b>	<b>T3 FPS Bumper</b>
<b>Vehicle:</b>	<b>JEEP JK Wrangler 07+</b>
<b>Part No.</b>	<b>070SO03N36Z</b>

### Australian Standards Relating to Installing Vehicle Frontal Protection Systems (VFPS): AS 4876.1-2002

- a) Do not attach V.F.P.S. to vehicle using anchorages not intended for this purpose (e.g. engine mounting bolts), other than those specified by the V.F.P.S. manufacturer in this instruction.
- b) Do not use this product for any vehicle make or model other than those specified by the V.F.P.S. manufacturer (as above).
- c) Do not remove any plaques or labels from the V.F.P.S.
- d) Do not modify the structure of the V.F.P.S. in any way.

- **Read instructions fully before commencing fitment.**
- **Left hand & Right hand components are determined as seated in the vehicle.**
- **Check for (& remove) any build up in all captive nuts fitted to the FPS.**
- **Estimated Fitting Time: 1.5hrs**

<b>Bolt tensions</b>	<b>Dia. (mm)</b>	<b>Nm</b>	<b>ft.lbs</b>	<b>Dia. (inch)</b>	<b>Nm</b>	<b>ft.lbs</b>
All bolt tensions are as follows unless otherwise specified.	5	5	4	1/4"	9	7
	6	9	7	5/16"	22	15
	8	22	16	3/8"	33	27
	10	44	32	7/16"	55	43
	12	77	57	1/2"	86	66

### Warranty

For product warranty please refer to our website:  
[www.tjm.com.au](http://www.tjm.com.au)

**For further information contact T.J.M. Head Office (07) 3865 9999. Distributors Australia wide.**



# FITTING INSTRUCTIONS

**Product:**

**T3 FPS Bumper**

**Vehicle:**

**JEEP JK Wrangler 07+**

Part No.

070SO03N36Z

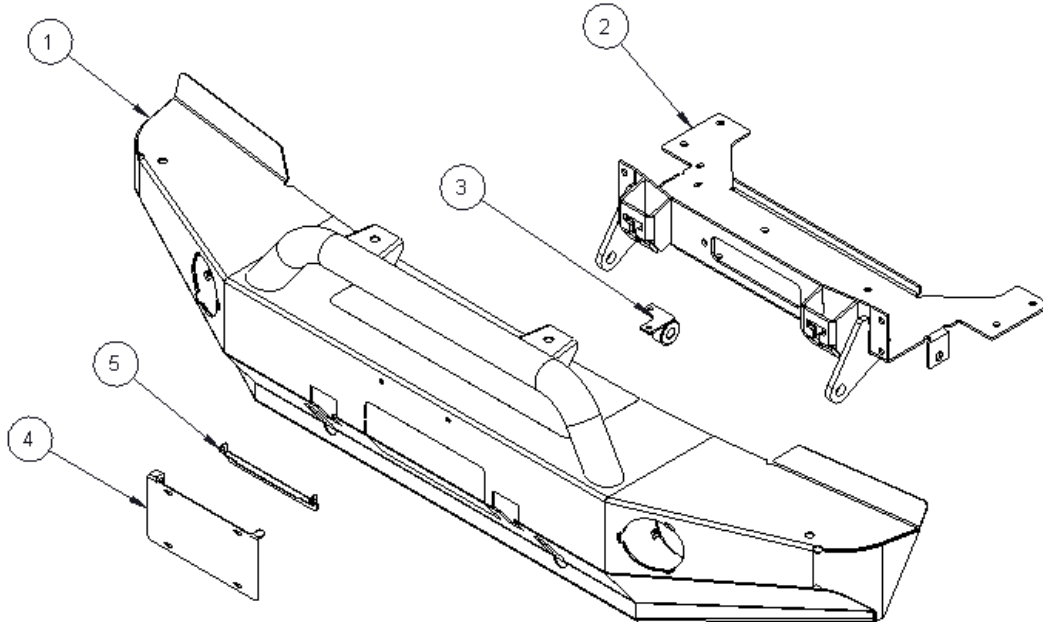

Item No.	Description	Qty	Part Number
<b>PARTS LIST</b>			
1	T3 FPS	1	84810
2	Winch Frame Assembly	1	84809
3	Electric Sway Bar Retaining Bracket Assembly	1	85853
4	Number Plate Bracket A	1	MTST-J309
5	Number Plate Bracket B	1	MTST-J305

Item No.	Description	Qty	Part Number
<b>BOLT KIT</b>			
N/A	M5 x 0.8 x 20mm Pan XR Metal	6	K0688
N/A	M5x20mm Stainless Steel Mush head Screw	8	K0691
N/A	3/16 x 1/2 x 20G Flat Washer	8	K0625
N/A	M5 x 0.8 Nyloc Hex Nut	6	K0604
N/A	M8 x 1.25 x 25mm Hex Head Bolt	2	K0553
N/A	M8 x 1.25 Hex Nut	2	K0585
N/A	M8 x 19 x 18G Flat Washer	5	K0628
N/A	M8 x 3.0 x 2.0 Medium Spring Washer	3	K0620
N/A	M10 x 1.25 Hex Nut	4	K0579
N/A	M10 x 3.5 x 2.2 Medium Spring Washer	4	K0621
N/A	M10 x 30 x 3.0mm Flat Washer	4	WSST-W13
N/A	M12 x 1.25 x 30mm Hex Head Bolt	6	K0569
N/A	M12 x 1.25 Hex Nut	6	K0581
N/A	M12 x 4.0 x 2.5 Medium Spring Washer	6	K0977
N/A	M12 x 24 x 1.6mm Flat Washer	12	K0425
N/A	UHMW Plastic Hinge Spacers	2	K1292
N/A	Clear Bump Ons	2	K1229
N/A	76-127mm Stainless Steel Hose Clamp	2	K1412
N/A	Polyurethane Bush	1	773B12
N/A	Polyurethane Mount Block	2	K2898
N/A	M8 Threaded Plate	1	F-1194
N/A	M8 x 1.25 x 20mm Hex Bolt	1	K0552

**For further information contact T.J.M. Head Office (07) 3865 9999. Distributors Australia wide.**



# FITTING INSTRUCTIONS

**Product:**

**T3 FPS Bumper**

**Vehicle:**

**JEEP JK Wrangler 07+**

Part No.

070SO03N36Z



1. Remove (& retain) the number-plate and fasteners.
2. Remove the screws (3) from the back of the bumper which secure the plastic covers in place.
3. Disconnect the wiring loom from the OE fog-lights.
4. Remove the push clips (2) from the bumper, located in front of the grille.
5. Remove the fasteners (2) on the inside of the bumper at each end, which secure the bumper to the bumper support bracket.



6. Remove and discard the bumper.
7. Remove the push clips (4) that retain the lower plastic guard to the bumper support bracket and push clips (2) that retain the plastic guard to the chassis.
8. Remove the plastic guard and discard.
9. Unclip the wiring harness from the bumper support.
10. Unbolt and remove the bumper support, ensuring you retain the horn for re-fitment.



11. Remove the fog lights from the bumper.
12. Drill the mounting holes in the fog light out to 6mm.
13. Re-fit the fog lights to the bulbar using M5 x 20mm Stainless Steel Mushroom Head Screws (8).

**For further information contact T.J.M. Head Office (07) 3865 9999. Distributors Australia wide.**



# FITTING INSTRUCTIONS

Product:

T3 FPS Bumper

Vehicle:

JEEP JK Wrangler 07+

Part No.

070SO03N36Z

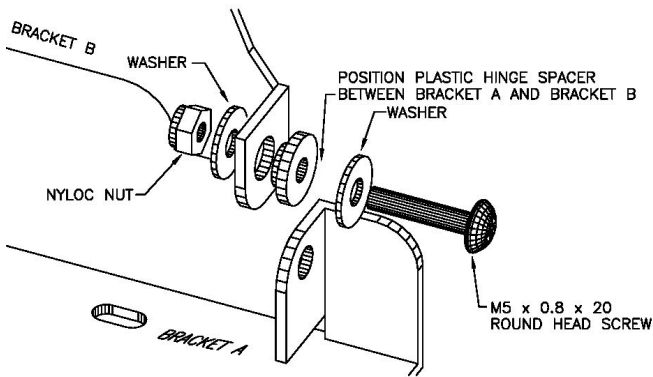

14. Assemble the number plate holder by securing bracket A and bracket B together as shown using M5 x 0.8 x 20mm pan screws (2), plastic hinge spaces (2), 3/16 x 1/2" flat washers (4) & M5 Nyloc nuts (2).

15. Secure the number-plate, to the number plate holder bracket assembly using M5 x 0.8 x 20mm pan screws (2), 3/16 x 1/2" flat washers (2) & M5 Nyloc nuts (2).

16. Mount the number plate holder bracket assembly to the FPS using M5 x 0.8 x 20mm pan screws (2), 3/16 x 1/2" flat washers (2) & M5 Nyloc nuts (2).

17. Align the bump-ons in the inside of bracket A so that they touch the winch fairlead rollers when the number plate holder bracket is lowered into position



**Steps 18 to 23 only apply if vacuum pump is installed.**

**Otherwise, please proceed to step 24.**

18. Disconnect pump from bracket and retain fasteners

19. Cut vacuum bracket off chassis at the marked locations.

20. De-burr the bracket edges & clean the area/surface of any swarf/debris, then treat raw exposed surfaces with a rust preventative.

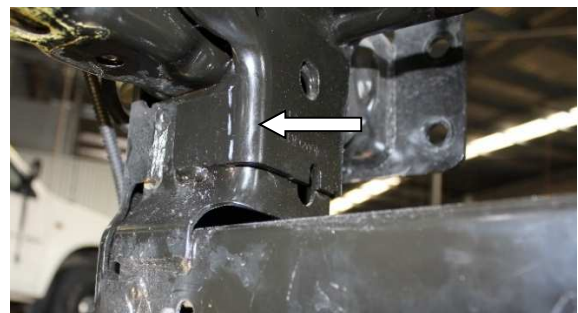

For further information contact T.J.M. Head Office (07) 3865 9999. Distributors Australia wide.



# FITTING INSTRUCTIONS

Product:

T3 FPS Bumper

Vehicle:

JEEP JK Wrangler 07+

Part No.

070SO03N36Z

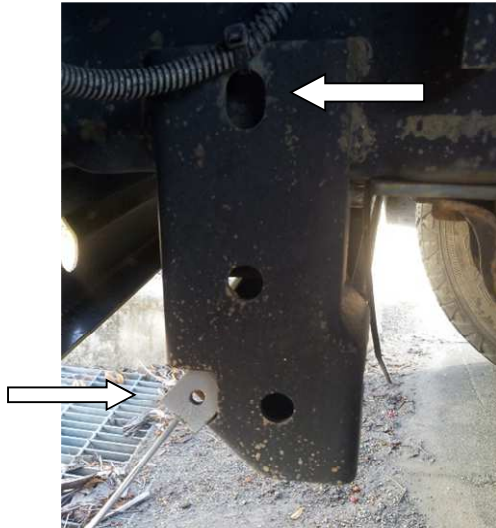

21. Insert the M8 threaded plate into the chassis mount lining up with the top hole
22. Reattach vacuum bracket with M8 x 1.25 x 30mm hex bolt (1), M8 x 19mm flat washer (1) & M8 spring washer.



23. Reroute the cables to the other side of the chassis rail and reattach the vacuum pump to the bracket using the OE fasteners.

**Steps 24 to 27 only apply if electronic sway bar disconnect is installed.  
Otherwise, please proceed to step 28**

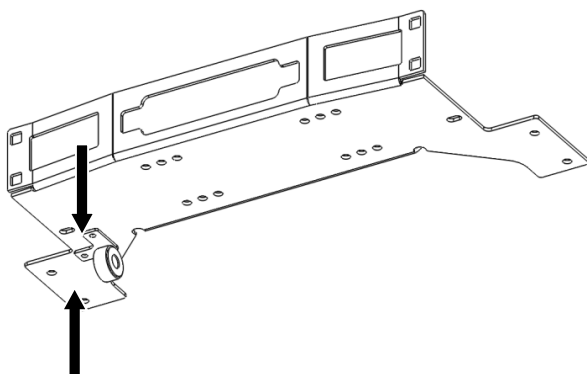

24. Remove (& retain) the fasteners securing the sway bar disconnect unit to the rubber mount.
25. Cut the 'S' shaped pin from the sway bar mount.
26. De-burr the edges & clean the area/surface of any swarf/debris, then (if applicable) treat any raw exposed surfaces with a rust preventative.
27. Using M8 x 1.25 x 25mm hex bolts (2), M8 x Ø19mm flat washers (4), M8 spring washers (2) & M8 hex nuts (2), secure the sway bar retaining bracket in place, as shown.

For further information contact T.J.M. Head Office (07) 3865 9999. Distributors Australia wide.



# FITTING INSTRUCTIONS

**Product:**

**T3 FPS Bumper**

**Vehicle:**

**JEEP JK Wrangler 07+**

Part No.

070SO03N36Z



28. Unbolt the front sway bar (retaining the fasteners) from the driver's side of the differential and from both sides of the chassis, so the sway bar can hang in front of the vehicle.

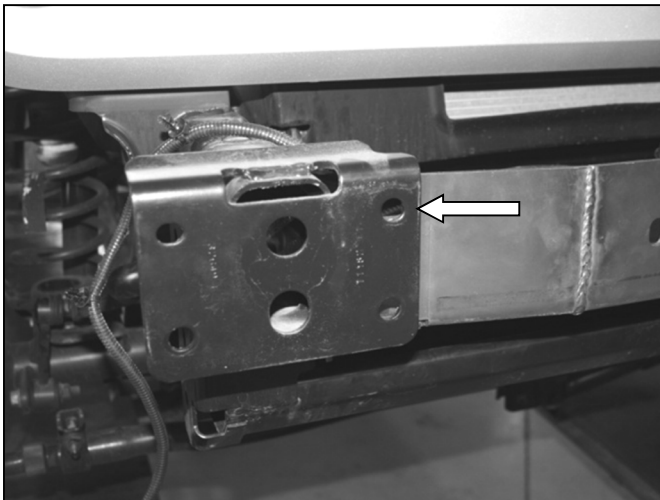

29. Slide the winch frame into position from behind the cross-member and align with the two upper holes on each side of the chassis end plates.

30. Secure the frame in place using M12 x 1.25 x 30mm hex bolts (4), M12 x 24mm flat washers (8), M12 spring washers (4) & M12 hex nuts (4).

31. Fix the winch frame to the side of the chassis using M12 x 1.25 x 30mm hex head bolts (2), M12 x 24mm flat washers (4), M12 spring washers (2) & M12 hex nuts (2).



32. Reposition the sway bar onto the vehicle and using the OE fasteners removed in step 14, fasten the assembly through the winch frame into the chassis where it was previously installed.

33. Tighten all bolts securing the winch frame and the sway bar

For further information contact T.J.M. Head Office (07) 3865 9999. Distributors Australia wide.



# FITTING INSTRUCTIONS

Product:

T3 FPS Bumper

Vehicle:

JEEP JK Wrangler 07+

Part No.

070SO03N36Z

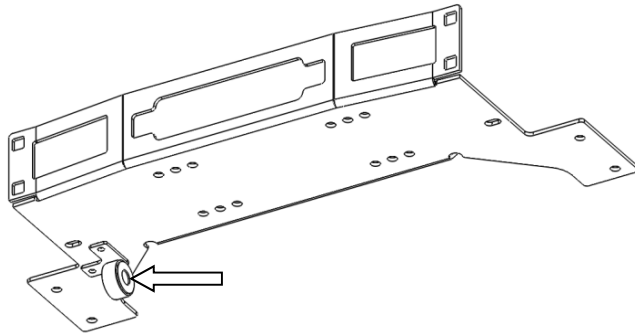

***Steps 34 to 36 only apply if electronic sway bar disconnect is installed. Otherwise, please proceed to step 37.***

34. Insert the polyurethane bush into the sway bar retaining bracket.
35. Use the OE fasteners and secure through the replacement bracket and through the original hole in the electronic sway bar disconnect unit.
36. Route the wiring harness under the winch frame and into the cross member.

***It may be necessary to lengthen the wiring on the horn.***

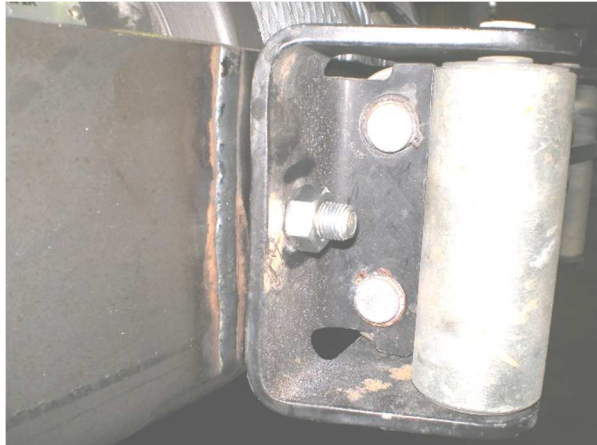

***Steps 37 to 40 only apply if fitting a winch. Otherwise, please proceed to step 41.***

37. Ensure the roller fairlead is fitted to the winch frame first with the bolts coming through from the rear.
38. Refer to the winch fitting instructions and fit the winch to the winch frame.
39. Secure the control box to the winch motor using the polyurethane mount blocks (2) and hose clamps (2) supplied.
40. Remove the micro jointed sections from the upper and lower center section of the bar. Remove any sharp edges left and treat any raw surfaces.

For further information contact T.J.M. Head Office (07) 3865 9999. Distributors Australia wide.



# FITTING INSTRUCTIONS

**Product:**

**T3 FPS Bumper**

**Vehicle:**

**JEEP JK Wrangler 07+**

Part No.

070SO03N36Z



41. Using two people, carefully lift the FPS into position, aligning the threaded studs with the holes in the Chassis end plates.
42. Ensure there is adequate clearance between the fog light and the re-positioned vacuum pump.
43. Loosely secure the FPS in place using M10 x 1.25 hex nut (4), M10 x 30 flat washers (4), M10 spring washers (4).
44. It may be necessary to manipulate the bar for it to sit level on the vehicle.
45. Refit the horn to the vehicle.
46. Ensure that all of the wiring looms are connected and check the operation of the fog-lights to ensure that they are functioning correctly.
47. Ensure that all fasteners are fully tightened to the appropriate torque settings & that, as a result of fitting the product, no vehicle components are crushed or will chafe.

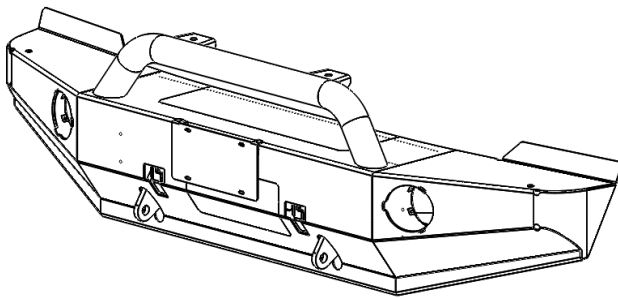

For further information contact T.J.M. Head Office (07) 3865 9999. Distributors Australia wide.