



FITTING INSTRUCTIONS

Product:	Torq Winch 9,500lb Steel / 9,500lb Synthetic / 12,000lb Synthetic
Vehicle:	Generic
Part No.	947TJMTQ95SAB / 947TJMTQ95DAA / 947TQBK95DAA / 947TJMTQ12DAA / 947TQBK12DAA

VEHICLE RECOVERY ELECTRIC WINCH



For product warranty please refer to our website www.tjm.com.au



FITTING INSTRUCTIONS

Product:	Torq Winch 9,500lb Steel / 9,500lb Synthetic / 12,000lb Synthetic
Vehicle:	Generic
Part No.	947TJMTQ95SAB / 947TJMTQ95DAA / 947TQBK95DAA / 947TJMTQ12DAA / 947TQBK12DAA

TABLE OF CONTENTS

SAFETY PRECAUTIONS	3
WINCH OPERATION WARNINGS	4
INSTALLATION	6
CLOCKING GEARBOX HOUSING	6
MOUNTING YOUR WINCH	9
LUBRICATION INSTALLATION	9
CABLE INSTALLATION	9
ELECTRICAL CONNECTION	10
CONTROL BOX MOTOR MOUNT INSTRUCTIONS	11
ISOLATOR SWITCH INSTALLATION	12
CABLE PUCK ASSEMBLY	12
WINCH OPERATION	14
SUGGESTION.....	14
OPERATING	14
WIRELESS HAND CONTROLLER	14
MAINTENANCE	15
WINCH	15
SYNTHETIC ROPE	15
9500lb WINCH FEATURES & SPECIFICATIONS	16
9500lb WINCH LINE SPEED & AMP DRAW (1st LAYER)	16
9500lb WINCH LINE PULL BY LAYER	16
12000lb WINCH FEATURES & SPECIFICATIONS	17
12000lb WINCH LINE SPEED & AMP DRAW (1st LAYER)	17
12000lb SYNTHETIC LINE PULL BY LAYER	17
CONTROL BOX RELOCATION DRILLING TEMPLATE	18

For product warranty please refer to our website www.tjm.com.au



FITTING INSTRUCTIONS

Product:	Torq Winch 9,500lb Steel / 9,500lb Synthetic / 12,000lb Synthetic
Vehicle:	Generic
Part No.	947TJMTQ95SAB / 947TJMTQ95DAA / 947TQBK95DAA / 947TJMTQ12DAA / 947TQBK12DAA

SAFETY PRECAUTIONS

Warning! Observe safety precautions for personal safety and the safety of others. Improper equipment operation may cause personal injury and equipment damage. Read the following carefully before attempting to operate your winch and keep the instructions for future reference.

- 1. Avoid Unintentional Starting:**
 - **Ensure the isolator switch is in the off position when not in use!**
- 2. Dress Properly:**
 - Don't wear loose clothing or jewellery. They can be caught in moving parts.
 - Wear leather gloves when handling winch cable. Do not handle cable with bare hands as broken wires can cause injuries.
 - Non-skid footwear is recommended.
 - Wear protective hair covering to contain long hair.
- 3. Keep a Safe Distance:**
 - Ensure that all persons stand well clear of winch cable and load during winch operation – 1.5 times the cable length recommended. If a cable pulls loose or breaks under load, it can lash back and cause serious personal injury or death.
 - Don't step over the cable while it is connected.
 - All visitors and onlookers should be kept away from the winching area.
 - Keep proper footing and balance at all times.
- 4. Do not Abuse the Hand Controller:**
 - Never yank the hand controller to disconnect it from the receptacle.
 - Keep cord from heat, oil and sharp edges.
- 5. Do not Overwork the winch:**
 - If the motor becomes uncomfortably hot to touch, stop and let it cool for a few minutes.
 - Don't maintain power to the winch if the motor stalls.
 - Don't exceed maximum line pull ratings shown in tables. Shock loads must not exceed these ratings.
- 6. Check Damaged Parts:**
 - Before using, you should check your winch carefully. Any part that is damaged should be properly repaired or replaced by an authorised service centre.
- 7. Repair Your Winch:**
 - When repairing, use only identical replacement parts. Otherwise, considerable danger for the user may be caused.
- 8. Re-spool the Cable:**
 - Leather gloves must be worn while re-spooling. To re-spool correctly, it is necessary to keep a slight load on the cable. Hold the cable with one hand and the remote control switch with the other. Start as far back and in the centre as you can. Walk up, keeping load on the cable as the winch is powered on.
 - Do not allow the cable to slip through your hand and do not approach the winch too closely.
 - Spool in cable under power but keep hands clear.

Warning: The use of any other accessory or attachment other than those recommended in this instruction manual will void the warranty and may present a risk of personal injury.

For product warranty please refer to our website www.tjm.com.au



FITTING INSTRUCTIONS

Product:	Torq Winch 9,500lb Steel / 9,500lb Synthetic / 12,000lb Synthetic
Vehicle:	Generic
Part No.	947TJMTQ95SAB / 947TJMTQ95DAA / 947TQBK95DAA / 947TJMTQ12DAA / 947TQBK12DAA

WINCH OPERATION WARNINGS

Read the following carefully before attempting to operate your winch and keep the instructions for future reference.

1. The uneven spooling of cable while pulling a load is not a problem unless there is a cable pile up on one end of the drum. If this happens reverse the winch to relieve the load and move your anchor point further to the centre of the vehicle. After the job is done you can unspool and rewind for a neat lay of the cable.
2. Store the remote control switch inside your vehicle where it will not become damaged. Inspect it before you plug it in.
3. When ready to begin spooling in, plug in remote control switch with clutch disengage. Do not engage clutch with motor running.
4. Never connect the hook back to the cable. This causes cable damage. Always use a tree trunk protector strap or winch cable extension strap, which can be found in the TJM Recovery kit.
5. Observe the operation of the winch from the safety of the vehicle cabin. Stop the winching process every metre or so to assure the cable is not pulling up in one corner of the winch drum. If the cable bunches, damage to the winch can occur.
6. The use of a snatch block will aid recovery operations by providing a doubling of the winch capacity and a halving of the winching speed, and the means to maintain a direct line pull to the centre of the rollers. When double loading during stationary winching, the winch hook should be attached to a recovery point recommended by the manufacturer of the vehicle.
7. Ensure rated "D" or bow shackles are used in conjunction with an approved tree trunk protector to provide a safe anchor point.
8. When extending winch cable, ensure that at least ten wraps of cable remain on drum at all times. Failure to do this could result in the cable parting from the drum under load. Serious personal injury or property damage may result.
9. Since the greatest pulling power is achieved on the innermost layer of your winch, it is desirable to pull off as much line as you can for heavy pulls (you must leave at least 10 wraps minimum on the drum – do not pull the rope out any further once you see the red marker). If this is not practical, use a snatch block and double line arrangement.
10. Drape a recovery blanket or similar object over the extended winch cable to dampen any back lash should a failure occur. When using steel cable, it is recommended that the recovery blanket be placed in the middle of the cable. When using synthetic rope, the blanket should be placed closest to the hook.
11. Neat, tight spooling avoids cable binding.
12. Apply blocks to wheels when vehicles are on an incline.

For product warranty please refer to our website www.tjm.com.au



FITTING INSTRUCTIONS

Product:	Torq Winch 9,500lb Steel / 9,500lb Synthetic / 12,000lb Synthetic
Vehicle:	Generic
Part No.	947TJMTQ95SAB / 947TJMTQ95DAA / 947TQBK95DAA / 947TJMTQ12DAA / 947TQBK12DAA

13. Battery:

- Be sure that the battery is in good condition. Avoid contact with battery acid or other contaminants.
- Always wear eye protection when working around a battery.
- Have the engine running when using the winch, to avoid flattening the battery.
- It is recommended that a TJM Dual Battery System is fitted.
- **The minimum battery requirement is 650 CCA.**

14. Winch Cable:

- Be sure that the cable is in good condition and is attached properly.
- Do not use the winch if cable is frayed.
- Do not move the vehicle to pull a load.
- Do not replace the cable with a cable of lesser strength.
- The life of the cable is directly related to the use and care it receives. Prior to use, the cable must be wound on to the drum under a load of at least 500lbs (230kg). Otherwise, the outer wraps will draw into the inner wraps and severely damage the cable during winching. The first use of the winch should be in a relaxed, non-recovery situation. Spool out the cable until you see the red marker (this leaves ten wraps on the drum), then rewind the cable on to the drum under a load of 500lbs (230kg) or more. This will slightly tension and stretch the new cable and create a tight cable wrap around the drum. Failure to do so may result in cable damage and reduced cable life.
- For steel cable winches - when the cable is replaced, be sure to apply Loctite, or an equal compound, to the cable clamp thread. Tighten the clamp screw properly but do not over tighten. The Loctite will prevent loosening of the screw in arduous conditions. Loctite 7471 Primer and 222 Thread Locker are recommended.
- For synthetic rope winches – when the rope is replaced, pull a length of rope through the hole in the drum and lay it across the drum (if desired, use tape to hold the tip in position). Then wind the rope on top of the ‘tail’ on the drum.

NOTE: The clamp screw is not designed to hold any load. It is purely an anchor point for the winch cable.

15. Do not attempt to exceed the pulling limits of this winch.

16. It is not recommended to drive your vehicle to assist the winch. Vehicle movement in combination with winch operation may overload the cable or the winch itself or cause damaging shock loads.

17. Shock loads when winching is dangerous! A shock load occurs when an increased force is suddenly applied to the cable. A vehicle rolling back on a slack cable may induce a damaging shock load.

18. The winches shown in this manual are solely for vehicle mounting & non-industrial applications.

19. Do not use winch in hoisting applications due to required hoist safety factors and features.

20. Do not use the winch to lift, support or otherwise transport personnel.

For product warranty please refer to our website www.tjm.com.au



FITTING INSTRUCTIONS

Product:	Torq Winch 9,500lb Steel / 9,500lb Synthetic / 12,000lb Synthetic
Vehicle:	Generic
Part No.	947TJMTQ95SAB / 947TJMTQ95DAA / 947TQBK95DAA / 947TJMTQ12DAA / 947TQBK12DAA

INSTALLATION

CLOCKING GEARBOX HOUSING

Winch gear housing can be clocked in 8 ways allowing the user to position the clutch lever at 8 equidistant locations (0°, 45°, 90°,, 360°).

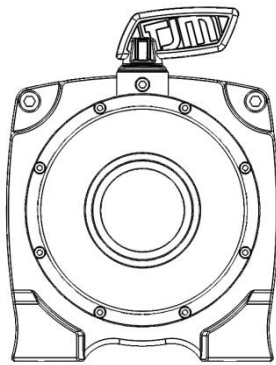

Gearbox @ 0°

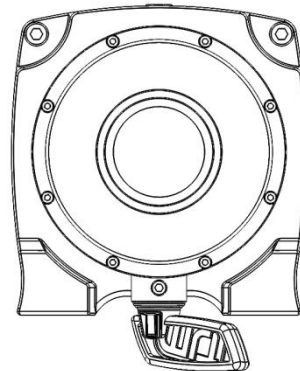

Gearbox @ 180°

Ensure you have a clean work area before commencing.

1. Remove the two Allen head cap screws (circled), holding the tie rod on the gearbox side of the winch.

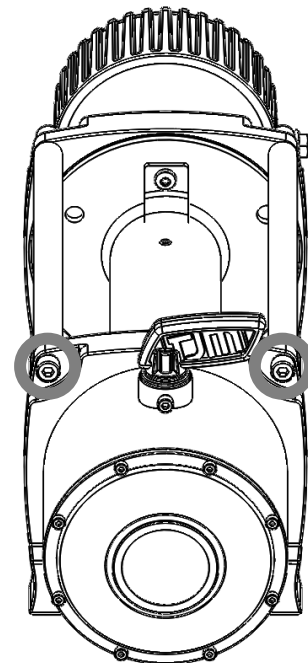

Diagram 1.

For product warranty please refer to our website www.tjm.com.au



FITTING INSTRUCTIONS

Product:	Torq Winch 9,500lb Steel / 9,500lb Synthetic / 12,000lb Synthetic
Vehicle:	Generic
Part No.	947TJMTQ95SAB / 947TJMTQ95DAA / 947TQBK95DAA / 947TJMTQ12DAA / 947TQBK12DAA

- Carefully remove the gearbox away from the cable drum.



Diagram 2.

- Unscrew all the 8 Allen head cap screws holding the gearbox foot casting to the gearbox housing.



Diagram 3.

- Rotate the gearbox foot casting to the desired position.



Diagram 4.

For product warranty please refer to our website www.tjm.com.au



FITTING INSTRUCTIONS

Product:	Torq Winch 9,500lb Steel / 9,500lb Synthetic / 12,000lb Synthetic
Vehicle:	Generic
Part No.	947TJMTQ95SAB / 947TJMTQ95DAA / 947TQBK95DAA / 947TJMTQ12DAA / 947TQBK12DAA

5. Line up the 8 holes, ensuring that the gasket is also lined up between the gearbox foot casting & gearbox housing.
6. Tighten all 8 Allen head cap screws in a diagonal sequence. Torque specification: 3.5Nm.

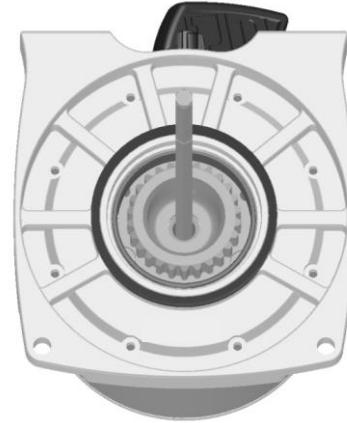

Diagram 5.

7. Carefully assembly the gearbox back into the cable drum, ensuring the sun (centre) gear is lined up in the cable drum.

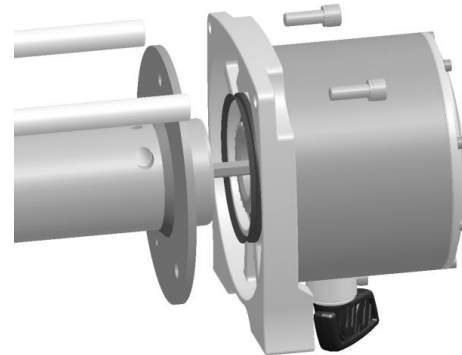

Diagram 6.

8. Refit & tighten the two Allen head cap screws to the tie rods. Torque specification 22Nm.

9. Check the operation of the clutch handle to ensure gearbox engages & fit winch to bar.

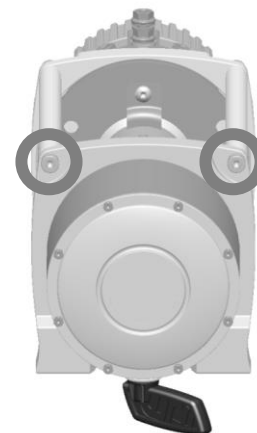

Diagram 7

For product warranty please refer to our website www.tjm.com.au



FITTING INSTRUCTIONS

Product:	Torq Winch 9,500lb Steel / 9,500lb Synthetic / 12,000lb Synthetic
Vehicle:	Generic
Part No.	947TJMTQ95SAB / 947TJMTQ95DAA / 947TQBK95DAA / 947TJMTQ12DAA / 947TQBK12DAA

MOUNTING YOUR WINCH

- The winch is to be mounted into a suitable steel mounting frame using the 4 point foot mounting system in either a horizontal or vertical plane.
 - It's very important that the winch be mounted on a flat surface so that the three sections (motor, cable drum and gear housing) are properly aligned.
 - Before commencing installation, ensure the mounting facility being used is capable of withstanding the winch's rated capacity.
 - The fitment of winches and / or a frontal protection system may affect the triggering of SRS air bags. Check that the mounting system has been tested and approved for winch fitment in the airbag equipped vehicle.
- TJM Products manufacture winch mounting frames and / or Frontal Protection Systems to suit most popular vehicles. Winch frames are packaged with detailed fitting instructions.
- The winch should be secured to the mount with the mounting hardware supplied with the winch.
- The fairlead is to be mounted to guide the rope onto the drum evenly.

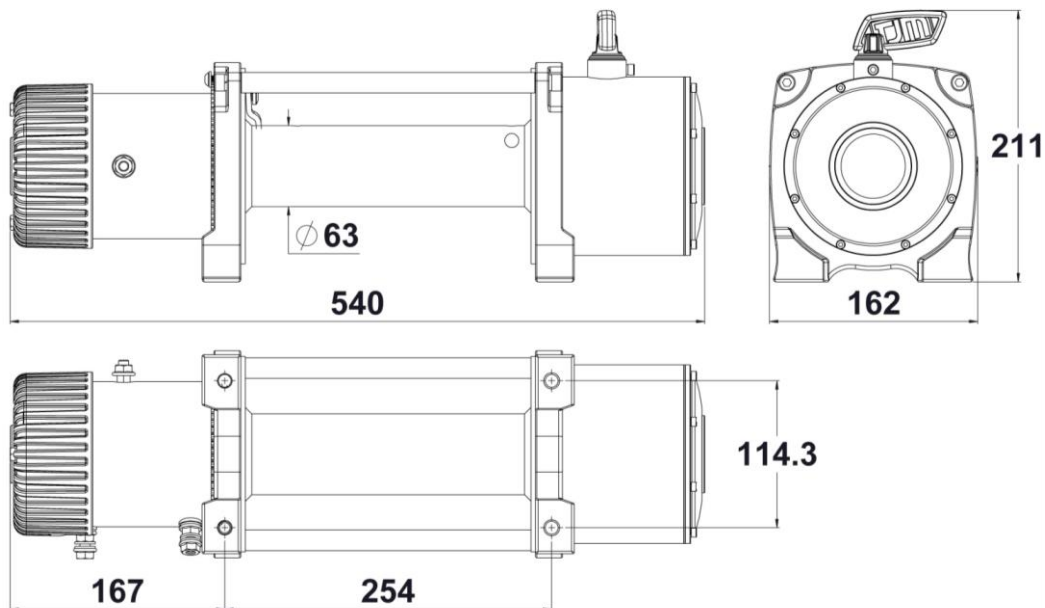

LUBRICATION INSTALLATION

All moving parts in the winch are permanently lubricated with heavy duty grease at the time of assembly. Under normal conditions, factory lubrication will suffice. Lubricate steel wire cable periodically using light penetrating oil. Inspect for broken strands and replace if necessary. If the cable becomes worn or damaged, it must be replaced.

CABLE INSTALLATION

Unwind the new cable by rolling it along the ground, to prevent kinking. Remove old cable and observe the manner in which it is attached to the cable drum.

For product warranty please refer to our website www.tjm.com.au



FITTING INSTRUCTIONS

Product:	Torq Winch 9,500lb Steel / 9,500lb Synthetic / 12,000lb Synthetic
Vehicle:	Generic
Part No.	947TJMTQ95SAB / 947TJMTQ95DAA / 947TQBK95DAA / 947TJMTQ12DAA / 947TQBK12DAA

ELECTRICAL CONNECTION

For self-recovery work, the fitment of a TJM Dual Battery System is recommended. A fully charged battery and proper connections are essential. Run the vehicle engine during winching operations to keep batteries (2) charged.

Important

When securing the leads to the terminals on the winch motor, ensure that two open end spanners are used to secure the lead to the terminal (as shown). **Failure to do so will result in the internal connections of the motor shorting out and will void any warranty.**



Pay close attention to proper electrical lead connection as follows (refer to Diagram 1)

- Long black lead – connects to negative (-) terminal of battery & to bottom terminal of motor (A).
- Earth Lead (Thin black lead) – connects to bottom terminal of motor (A).
- Long red lead – connects to positive (+) terminal of battery.
- Short red lead – to red stud (B) of motor.
- Short yellow lead – connects to yellow stud (D) of motor.
- Short green lead – connects to green terminal stud (C) of motor.

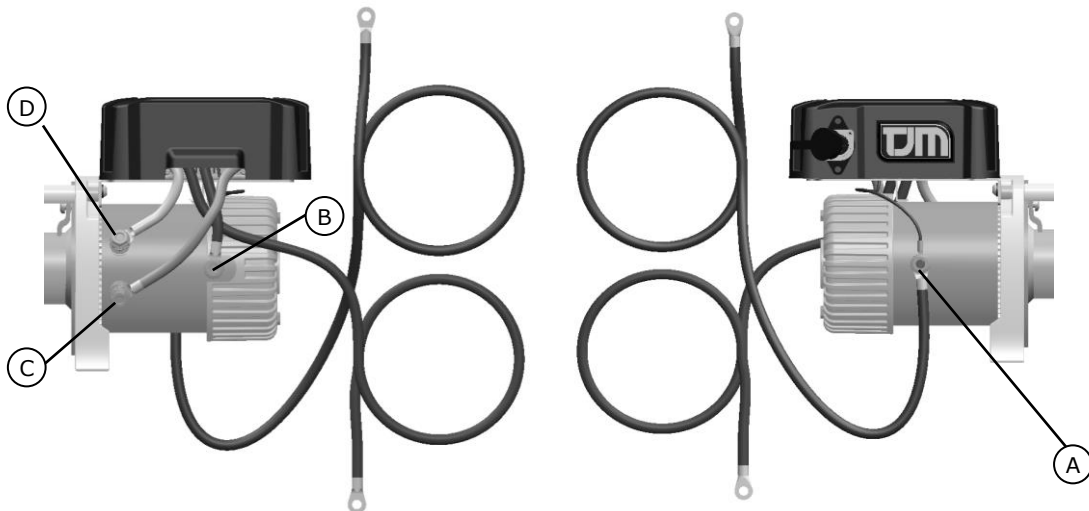

Diagram 8

For product warranty please refer to our website www.tjm.com.au



FITTING INSTRUCTIONS

Product:	Torq Winch 9,500lb Steel / 9,500lb Synthetic / 12,000lb Synthetic
Vehicle:	Generic
Part No.	947TJMTQ95SAB / 947TJMTQ95DAA / 947TQBK95DAA / 947TJMTQ12DAA / 947TQBK12DAA

NOTE:

1. Your battery must be kept in good condition.
2. Be sure battery cables are not drawn taught across any surfaces, which could possibly damage them.
3. Corrosion on electrical connections will reduce performance or may cause a short.
4. Clean all connections, especially in remote control switch and receptacle.
5. In salty environments, use a silicone sealer to protect from corrosion.

CONTROL BOX MOTOR MOUNT INSTRUCTIONS

Install control box on to mounting bracket using bolts supplied. Install as shown.

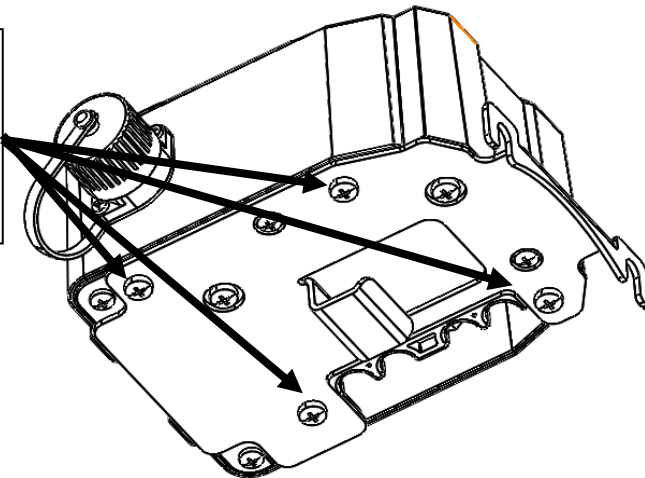

Loosen the 2 bolts and mount the control box. Tighten the 2 bolts after installing the hose clamp.

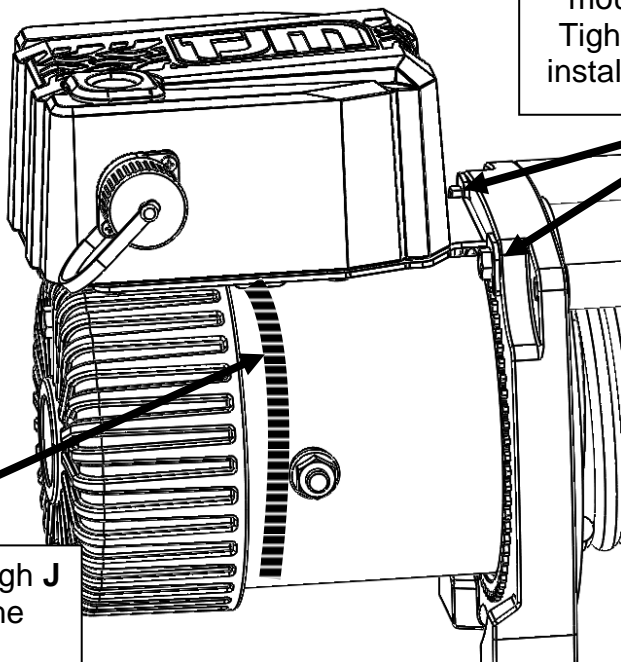

Install hose clamp through J bracket and around the motor and tighten.



FITTING INSTRUCTIONS

Product:	Torq Winch 9,500lb Steel / 9,500lb Synthetic / 12,000lb Synthetic
Vehicle:	Generic
Part No.	947TJMTQ95SAB / 947TJMTQ95DAA / 947TQBK95DAA / 947TJMTQ12DAA / 947TQBK12DAA

ISOLATOR SWITCH INSTALLATION

It is recommended that an isolator switch be installed with your winch to isolate the winch to prevent inadvertent operation of the winch. It is recommended that the isolator switch be fitted in a location where it is easily accessible when winching. The following is a guide only, it is up to the end user to best determine the location.

1. Disconnect the long BLACK from the negative (-) side from the vehicle battery.
2. Pick a suitable position for the isolator switch in an easily accessible location &
3. Using the isolator switch bracket as a guide, mark the four mounting holes where the isolator switch will be installed.
4. Remove the isolator switch bracket & drill four marked holes, making sure the drill bit will not damage wiring or other parts when the drill bit exits.
5. Deburr all holes & treat raw surfaces with rust preventative.
6. Ensure the isolator switch is set to the "OFF" position.
7. Using the long RED cable from the vehicle's battery (+) connect it to one side of the isolator switch (it does not matter which side of the isolator switch).
8. Connect the short red wire to solenoid box switch (+), see diagram 1 (position 3 marked on the solenoid box).
9. Connect the other end of the short red wire to the isolator switch.
10. Secure the isolator switch bracket using suitable fasteners.
11. Connect the long RED cable to the positive (+) side of the vehicle battery.
12. Re-connect the long BLACK from the negative (-) side from the vehicle battery.
13. Check that all connections are secure & cables are not rubbing or chaffing, or against any sharp edges.
14. Turn the isolator switch to the "ON" position & operate the winch in the "OUT" position. While the winch is still operating in the out position turn the isolator switch to the "OFF" & the winch should lose all power.

CABLE PUCK ASSEMBLY

Contents

- 1 x Puck



1. Push a section of rope together so that the individual strands separate.



For product warranty please refer to our website www.tjm.com.au



FITTING INSTRUCTIONS

Product:	Torq Winch 9,500lb Steel / 9,500lb Synthetic / 12,000lb Synthetic
Vehicle:	Generic
Part No.	947TJMTQ95SAB / 947TJMTQ95DAA / 947TQBK95DAA / 947TJMTQ12DAA / 947TQBK12DAA

2. Pull the strands apart to flatten the rope as much as possible.

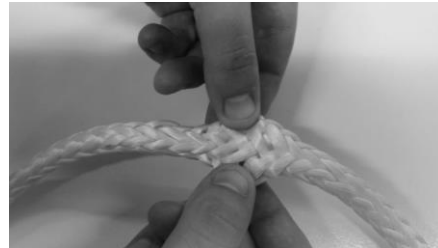

3. Feed the flattened rope into the slot in the puck.



4. Work the rope into the slot strand by strand.



5. Then slide the rope all the way through the slot.

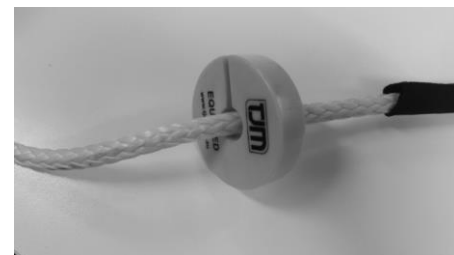

6. Finally slide the puck all the way to the end of the rope.



For product warranty please refer to our website www.tjm.com.au



FITTING INSTRUCTIONS

Product:	Torq Winch 9,500lb Steel / 9,500lb Synthetic / 12,000lb Synthetic
Vehicle:	Generic
Part No.	947TJMTQ95SAB / 947TJMTQ95DAA / 947TQBK95DAA / 947TJMTQ12DAA / 947TQBK12DAA

WINCH OPERATION

SUGGESTION

The best way to get acquainted with how your winch operates is to take a few test runs before you actually need to use it. Plan your test in advance. Remember, you can hear your winch as well as you can see it operate. Get to recognise the sound of a light steady pull, a heavy pull, and sounds caused by load jerking or shifting. Soon, you will gain confidence in operating your winch and its use will become second nature to you.

OPERATING

1. Ensure the vehicle is secure by applying the parking brake or chocking the wheels.
2. Pull the winch cable out to the desired length and connect to an anchor point.
The winch clutch allows rapid uncoiling of the cable for hooking onto the load or anchor point. The shifter tab located on the gear housing of the winch operates the clutch as follows:
 - a) To disengage the clutch, move the clutch lever to the "OUT" position. Cable may be free spooled off the drum.
 - b) To engage the clutch, move the clutch lever into the "IN" position. The winch is now ready for operation.
3. Recheck all cable rigging before proceeding.
4. Plug in the winch hand control. It is recommended that the winching operation takes place from the driver's position to ensure safe operation. It is also recommended that a heavy blanket be placed over the cable, and the bonnet placed in the upright position.

WIRELESS HAND CONTROLLER

5. If using the wireless hand control, hold both the IN and OUT buttons down until the operation light indicates that the controller is on (hold both IN and OUT buttons down when finished to switch the wireless hand control off).
 6. To commence winching operation, start vehicle engine, select neutral in transmission, maintain engine speed at just above idle.
 7. Operate the remote-control switch to IN or OUT until the vehicle has been retrieved. Regularly check the winch to ensure cable is winding onto the drum evenly.
- NOTE:** The winch is designed for intermittent use, not continuous use. This is to prevent over-heating.

NOTE:

1. Never winch with your vehicle in gear or in park, which would damage your vehicle's transmission.
2. Never wrap the cable around the object and hook onto the cable itself. This can cause damage to the object being pulled, and kink or fray the cable or rope.
3. Keep hands, clothing, hair and jewellery clear of the drum area and cable when winching.
4. Never use the winch if the cable is frayed, kinked or damaged.
5. Never allow anyone to stand near the cable/rope, or in line with the cable behind the winch while it is under power. If the cable should slip or break, it can suddenly whip back towards the winch, causing a hazard for anyone in the area.
6. Don't leave the switch plugged in when the winch is not in use.
7. Don't unspool the rope from the drum any further once the red marker is visible.

CHECK THE WINCH CAREFULLY AND THOROUGHLY BEFORE OPERATING!

For product warranty please refer to our website www.tjm.com.au



FITTING INSTRUCTIONS

Product:	Torq Winch 9,500lb Steel / 9,500lb Synthetic / 12,000lb Synthetic
Vehicle:	Generic
Part No.	947TJMTQ95SAB / 947TJMTQ95DAA / 947TQBK95DAA / 947TJMTQ12DAA / 947TQBK12DAA

MAINTENANCE

WINCH

It is highly recommended that the winch be operated regularly (once a month). Simply power the cable out 15m, free spool 5m and then power back in. This will keep all components in good working condition so that the winch can be relied on when needed.

SYNTHETIC ROPE

Regular maintenance will prolong the life of your winch rope. Periodically check the rope for damage or wear. Also, it's just as important to check the fairlead for damage, as a roughed-up fairlead can easily damage your rope.

Never combine a synthetic rope with a fairlead that has sharp edges, such as a fairlead worn down by steel cable.

An aluminium hawse fairlead is highly recommended for use with synthetic rope, since the aluminium hawse has no sharp edges and resists damage more easily than a roller fairlead.

Wash your synthetic rope regularly and always after driving through mud or saltwater. Unwind the rope and rinse it off with a garden hose to remove mud, salt, grit, and debris. Never use solvents, bleach, or harsh detergents to clean your rope. They can weaken the fibres and compromise the strength of the rope. Let the rope air dry before storing or respooling. Keep synthetic rope covered to slow down the fading of the rope. Even with UV inhibitors, exposure to the sun will eventually fade the colour on your rope. Synthetic line is designed to withstand harsh exposure to the elements, since it was originally developed for marine use, but it will last longer (and look better) if you keep it covered.

Contact your authorised outlet for technical assistance and repairs.

For product warranty please refer to our website www.tjm.com.au



FITTING INSTRUCTIONS

Product:	Torq Winch 9,500lb Steel / 9,500lb Synthetic / 12,000lb Synthetic
Vehicle:	Generic
Part No.	947TJMTQ95SAB / 947TJMTQ95DAA / 947TQBK95DAA / 947TJMTQ12DAA / 947TQBK12DAA

9500lb WINCH FEATURES & SPECIFICATIONS	
Single line rated pull	9500lbs (4310kg) single-line
Motor	4.9hp / 3.6kw, Series Wound
Gear Train	3 Stage Planetary
Gear Reduction Ratio	150:1
Braking Action	Automatic In-The-Drum
Drum	Hardened Drum
Rope supplied	Aircraft Steel Cable 3/8" x 92' / 9.53mm x 28m or Synthetic Rope 3/8" x 92' / 9.53mm x 28m
Fairlead (Steel Cable)	Steel Hawse Fairlead
Fairlead (Synthetic)	Aluminium Hawse Fairlead
Remote Control	Wired and Wireless Included
Battery	Recommended: 650CC minimum for winching
Finish	Black Onyx
Overall Dimensions	(LxWxH) 21.26" x 6.38" x 8.31" (540 x 162 x 211mm)
Mounting Bolt Pattern	10" x 4.50" (254 x 114.3mm)

9500lb WINCH LINE SPEED & AMP DRAW (1st LAYER)			
LINE LOAD lb / kg	LINE SPEED		MOTOR CURRENT
	MPM	FPM	
0 / 0	7.8	25.6	65
2000 / 907	4	13.1	185
4000 / 1814	2.6	8.5	200
6000 / 2722	2	6.6	260
8000 / 3630	1.7	5.6	270
9500 / 4310	1.65	5.4	300

9500lb WINCH LINE PULL BY LAYER		
CABLE LAYER	RATED LINE PULL	
	lb	kg
1	9500	4310
2	7374	3348
3	6246	2836
4	5417	2459
5	4783	2171



FITTING INSTRUCTIONS

Product:	Torq Winch 9,500lb Steel / 9,500lb Synthetic / 12,000lb Synthetic
Vehicle:	Generic
Part No.	947TJMTQ95SAB / 947TJMTQ95DAA / 947TQBK95DAA / 947TJMTQ12DAA / 947TQBK12DAA

12000lb WINCH FEATURES & SPECIFICATIONS	
Single line rated pull	12000lbs (5445kg) single-line
Motor	4.9hp / 3.6kw, Series Wound
Gear Train	3 Stage Planetary
Gear Reduction Ratio	210:1
Braking Action	Automatic In-The-Drum
Drum	Hardened Drum
Rope supplied	Synthetic Rope 3/8" x 92' / 9.53mm x 28m
Fairlead (Synthetic)	Aluminium Hawse Fairlead
Remote Control	Wired and Wireless Included
Battery	Recommended: 650CC minimum for winching
Finish	Black Onyx
Overall Dimensions	(LxWxH) 21.26" x 6.38" x 8.31" (540 x 162 x 211mm)
Mounting Bolt Pattern	10" x 4.50" (254 x 114.3mm)

12000lb WINCH LINE SPEED & AMP DRAW (1st LAYER)			
LINE LOAD lb / kg	LINE SPEED		MOTOR CURRENT
	MPM	FPM	
0 / 0	7.4	24.3	70
2000 / 907	4	13.1	150
4000 / 1810	2.7	8.9	190
6000 / 2722	2.3	7.5	250
8000 / 3630	1.9	6.1	270
10000 / 4540	1.5	4.9	310
12000 / 5440	1.1	3.6	360

12000lb SYNTHETIC LINE PULL BY LAYER		
CABLE LAYER	RATED LINE PULL	
	lb	kg
1	12000	5448
2	9607	4362
3	8010	3637
4	6868	3118
5	6011	2729



FITTING INSTRUCTIONS

Product:	Torq Winch 9,500lb Steel / 9,500lb Synthetic / 12,000lb Synthetic
Vehicle:	Generic
Part No.	947TJMTQ95SAB / 947TJMTQ95DAA / 947TQBK95DAA / 947TJMTQ12DAA / 947TQBK12DAA

CONTROL BOX RELOCATION DRILLING TEMPLATE

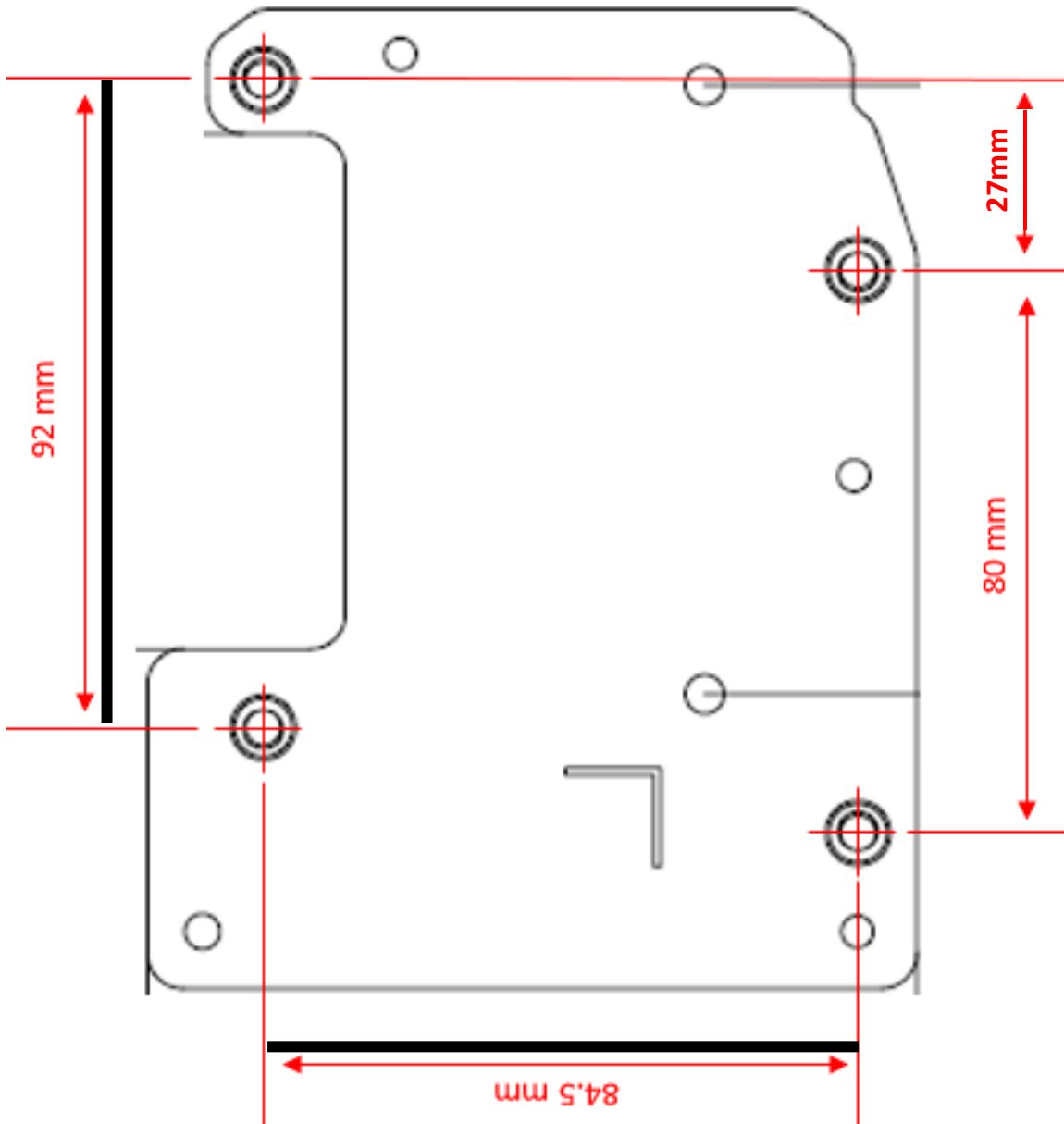

For product warranty please refer to our website www.tjm.com.au